

RFT Flameproof Process Sensing Thermostats

EXHEAT Industrial's RFT thermostats are supplied in weatherproof or flameproof enclosures to complement our heaters. All thermostats are certified for use in hazardous areas where the atmosphere is classified as a Zone 1 or 2 (IIA, IIB, IIC) gas group. The RFT is suitable for use in process tanks and vessels containing liquids.

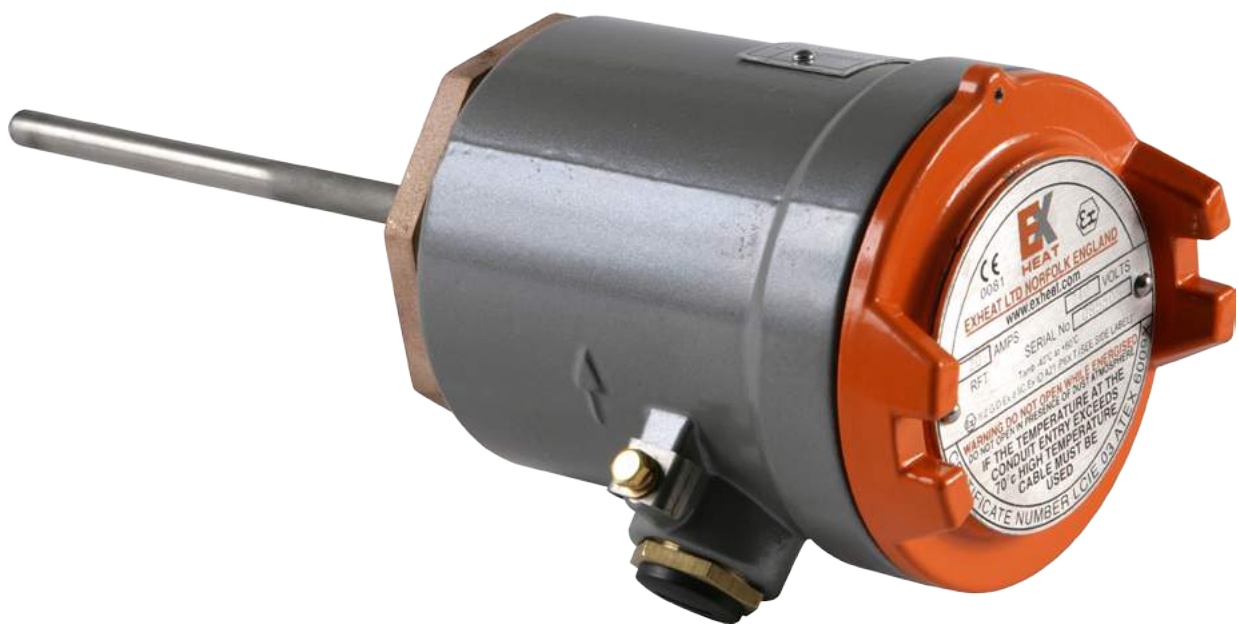

FEATURES

- Certified to ATEX standards
- Lightweight cast aluminium enclosure certified weatherproof to IP6X
- Suitable for ambient temperatures from -20°C to +40°C
- Mounting can be by a threaded boss or an industry standard flange
- 1 × M20 and 1 × M25 (plugged) cable entries provided as standard

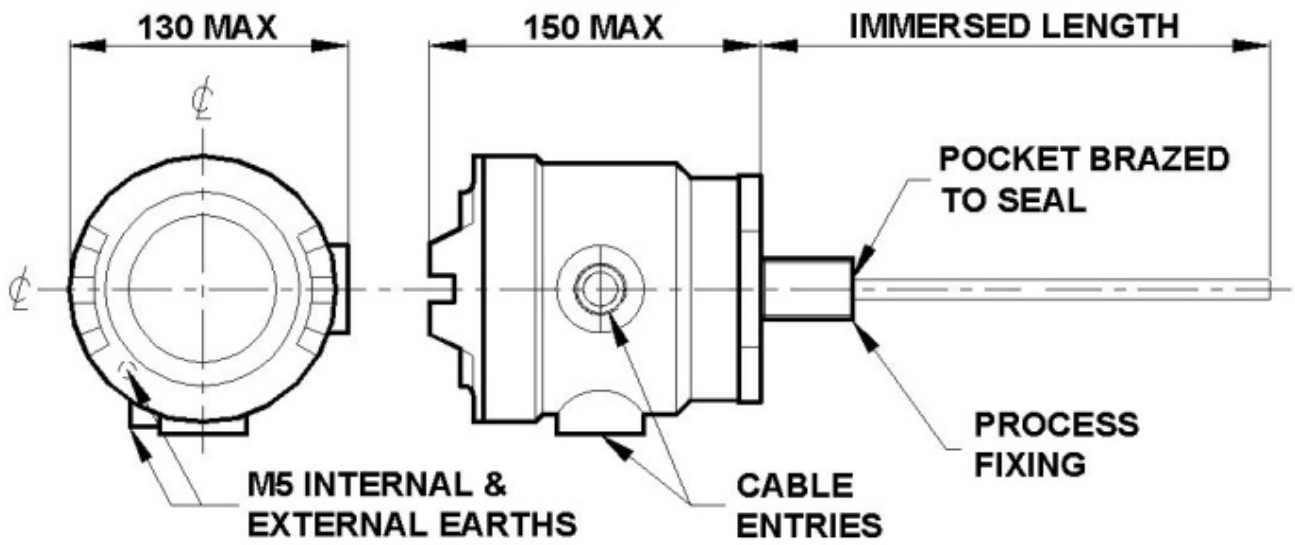

Certification

ATEX  II 2 G
 Ex d IIC T1 to T6 Gb Zone 1 and 2
 Ex d t IIIC T450 to T85°C Db Zone 21 and 22

Enclosure

Cast aluminium alloy with a maximum of two cable entries and external and internal earths

Controls

Choice of control range to suit process application

Mounting

Any threaded boss or flange in any material can be specified within the limits of the design parameters

Voltage

20A on 250VAC maximum in a choice of switching configurations